

intuis

AIRPULS 2

ELECTRONICALLY CONTROLLED FORCED-AIR HEATING

ORIGINE
FRANCE[®]
GARANTIE

BVCert. 6020118

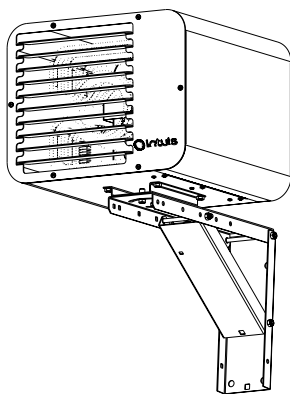

NOTICE
421AA6603 C00

EN

Electronically controlled forced-air heating

Installation and operating instructions

(please keep these instructions and read them carefully
before using the appliance)

INSTALLATION CONDITIONS:

“These heaters are specifically designed as components to be incorporated into an electric heating system consisting of a combination of heaters and control accessories for maintaining an ambient temperature in a closed room for the conservation of stored products, for the needs of a production line, or to keep a closed room at a frost-free temperature. These components can only be used after installation has been completed.

If the system is a decentralised electric hxe system with a rated thermal output exceeding 250 W and less than or equal to 50 kW, designed to maintain a comfortable temperature for people in a closed room, it must be fitted at least with an electronic room temperature control and a weekly programmer with at least one of the following three functions: open window detector, remote control option or adaptive activation control.

The installer who designs the heating system combination is responsible for selecting the appropriate components, assembling the combination in a way that complies with the relevant regulations and with all legislative requirements relating to the assembly, the EU Declaration of Conformity and the CE marking.

The fact that components bear the CE mark does not automatically guarantee the conformity of the electric heating system.”

CONTENTS

1- CHARACTERISTICS.....	Page 5
2- TIPS FOR LOCATING THE APPLIANCE.....	Page 6
3- LOCATION AND MOUNTING	Page 9
4- CONNECTION AND SERVICE	Page 11
5- OPERATION WITH A DIGITAL CABINET.....	Page 13
6- SPECIAL CASES	Page 21
7- MAINTENANCE	Page 22
8- APPLIANCE IDENTIFICATION.....	Page 22

DELIVERY

The appliance packaging contains a cardboard insert containing a hinged strut, a crossbar and a bag containing the wall bracket fastening components: Two M8 x 120 screws and two M8 lock nuts, three M8 screws and three washers. For the 4.5kW to 9kW models, you will also find a control strip (Location A opposite) to change the voltage to 230V single-phase.



1 - CHARACTERISTICS

This electric heater is designed for space heating or ventilation of large new or existing individual or collective premises (workshops, factories, hypermarkets, etc.).

Modularity

- The heater is delivered with a multi-position wall mounting bracket.

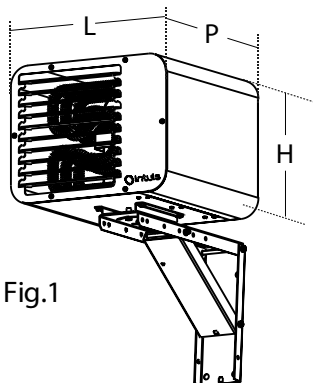

Fig.1

Reference	HEATER		VENTILATION		Noise (dB)	Increase in temp. (°K)	DIMENSIONS (excluding fastenings) W x H x D (mm)	WEIGHT (kg)
	Power rating (kW)	Voltage (V)	Throughput (m³/h)					
M194121	3 / 4,5	230 Single phase 400 Three phase 400 Three phase + Neutral	430 / 490	45 / 48	27 / 31	420 x 330 x 520	21	
M194122	4 / 6		620 / 700	46 / 49	25 / 29			
M194123	6 / 9	400 Three phase 400 Three phase + Neutral	920 / 1100	47 / 50	24 / 28	470 x 380 x 520	26	
M194124	8 / 12		1000 / 1200	50 / 53	29 / 31			
M194125	7,5 / 15	400 Three phase 400 Three phase + Neutral	1600 / 1800	52 / 55	25 / 28	520 x 430 x 660	36	
M194126	9 / 18		1600 / 1800	52 / 55	29 / 33			
M194127	12 / 24		1700 / 2200	53 / 56	31 / 41			

- The installed power depends on the insulation of the building, the heat loss and the geographical area.

- As a general rule, the installed power is between 40 W/m³ for well-insulated premises and 60 W/m³ for poorly insulated rooms with a mixing ratio greater than or equal to 4 times the volume of the room to be heated.

- Example:

For a 300 m³ room, a minimum mixing ratio of 1200 m³/hour is required.

2 - TIPS FOR LOCATING THE APPLIANCE

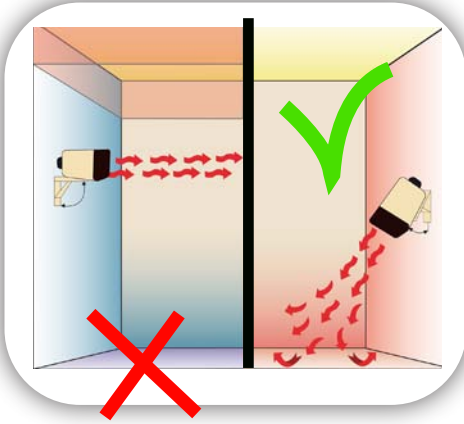

- Depending on the mounting height, the heater should be tilted downwards to prevent heat building up towards the ceiling. The higher an appliance is mounted, the more it must be inclined towards the ground.



- The heater should not blow directly onto people.



- The heater should not direct air streams directly at cold walls or very closely along them.

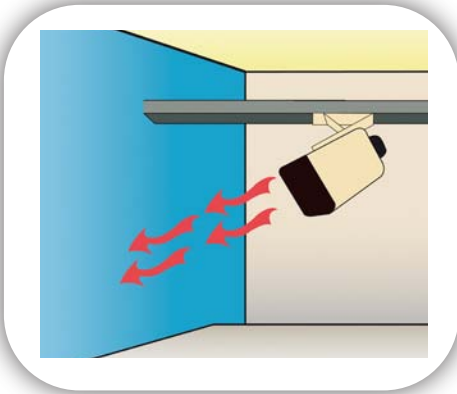

- If several heaters are installed, their air streams must not cross (See the recommended installation opposite).

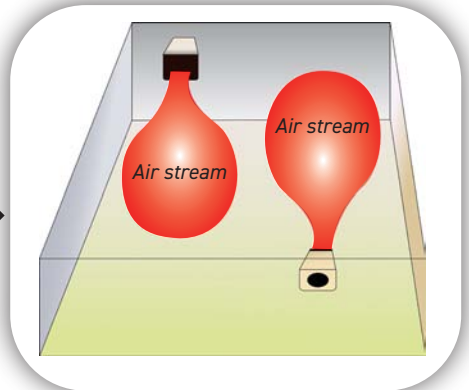

MOUNTING HEIGHT AND LIMITS

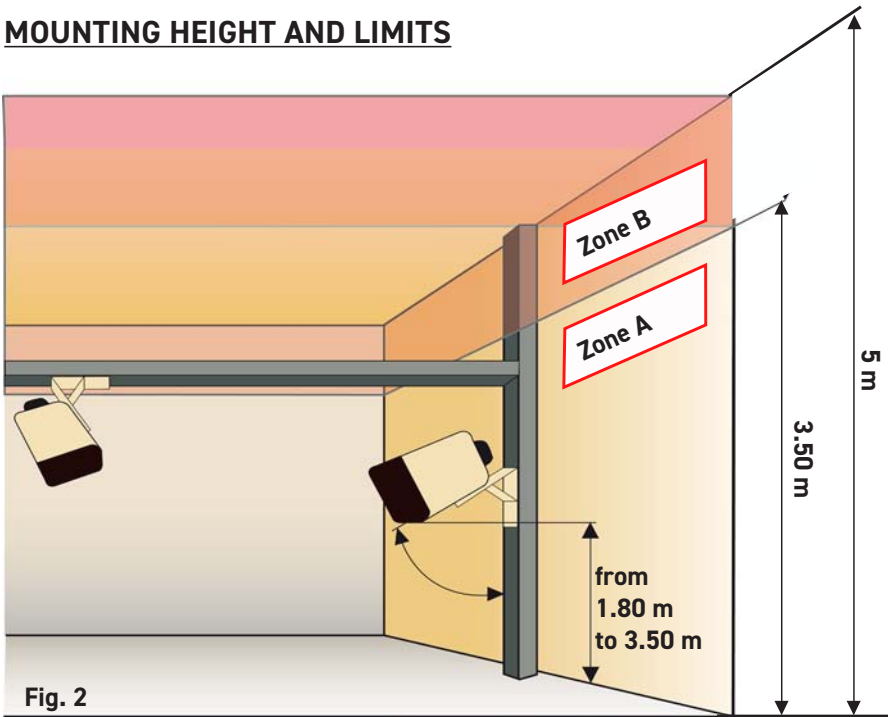

In zone A, the heater must be installed between 1.8 m and 3 m above the floor and at least 50 cm from the ceiling.

In zone B, we recommend using the appliance as a destratifier.

DESTRATIFICATION

- In a room with a high ceiling, if an appliance is installed beyond the limit for mounting (5 m), the heat will not reach the area to be heated and accumulates at a higher level (Fig. 3).

- If mounted vertically on the ceiling (90°) or at a steep angle to a wall (greater than 57°), a heater acts as a destratifier, sending the heat downwards (Fig. 4).

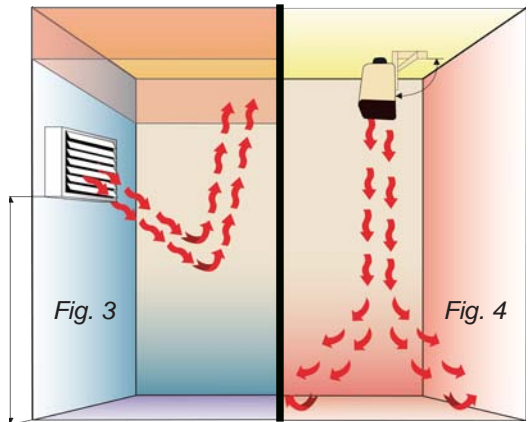

NOTE: see page 18 for instructions on how to use the control box in destratification mode.

MASTER/SLAVE OPERATION

- In master/slave mode, one control box can control up to 20 appliances in the same room.

● Installation conditions for the “master” appliance:

- The “master” heater should preferably be mounted as low as possible within the height limits for mounting.
- The appliance should be installed on the coldest wall in the room in which it is installed.

● Optimised communication

- The box is connected to the appliance by 2 non-polarised low-voltage wires* and the appliances are connected to each other by a single wire.

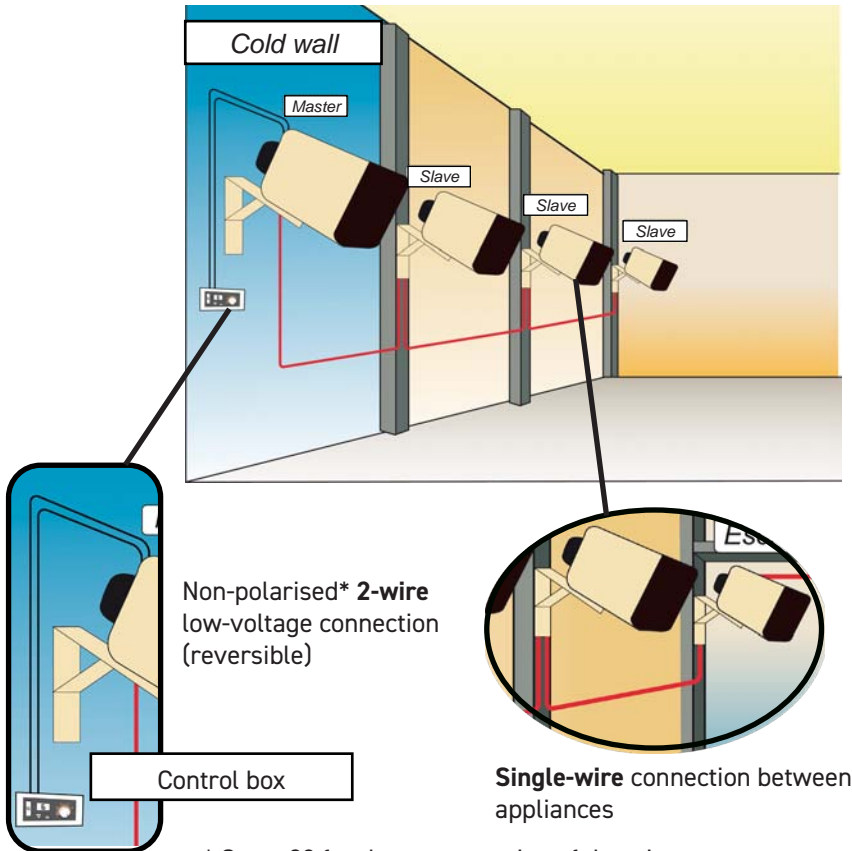

* See p.38 for the cross-section of the wires

3 - LOCATING AND MOUNTING THE SUPPORT

- The support is delivered in the cardboard box and consists of a hinged bracket, a strut and a bag of screws.
- The swivel is fitted to the underside of the heater as standard.

Two mounting options are available:

- Vertical and horizontal mounting

VERTICAL MOUNTING ON A WALL, POST, ETC.

- Use the hinged square (Fig. 5) to mark the fixing holes.
- Fix with 4 screws or tie rods depending on the type of support.
- Place the strut in the hinged bracket with the folds facing inwards and the larger holes positioned on the side of the square perforations (location A) of the bracket (Fig. 5).
- Insert an M8 x120 screw (on the square perforation side) into the holes, Location 8 or 9, then hand-tighten an M8 lock nut (Fig. 6).

Choice of inclination:

- Insert the second M8 x 120 screw in the hole corresponding to the desired inclination:

LOCATION	1	2	3	4	5	6	7
8	32°	10°	0° horizontal	/	/	70°	60°
9	33°	23°	18°	12° horizontal	0°	50°	47°

For vertical mounting (90°), use the holes at Locations 9 and 3 without using the spacer.

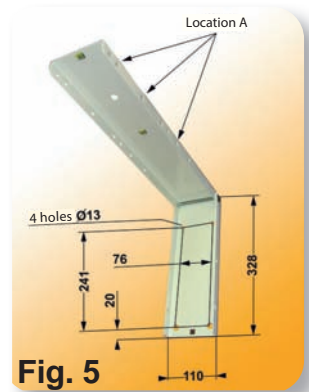

Fig. 5

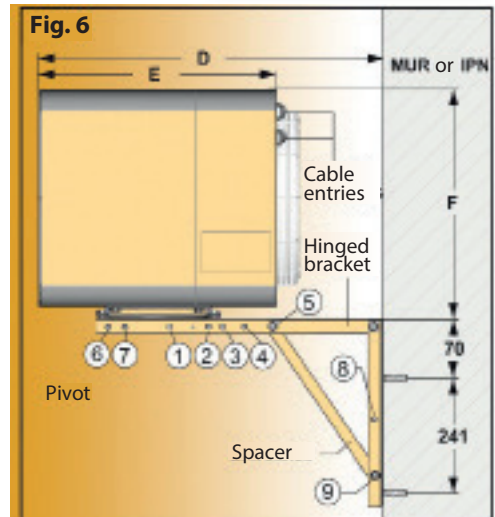
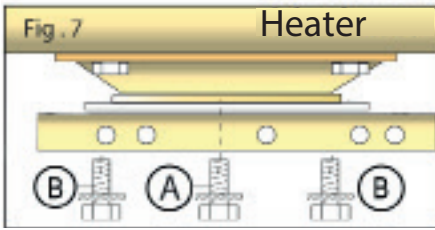

Fig. 6

- Screw on the second M8 nut and lock the two M8 locknuts.
- Fig. 5 gives the overall dimensions and drilling dimensions (in mm) for fixing the hinged bracket.

Appliance	D	E	F
3/4.5 KW	635	430	350
4/6 KW	635	430	350
6/9 KW	635	430	400
8/12 KW	635	430	400
7.5/15 KW	685	480	450
9/18 KW	685	480	450
12/24 KW	685	480	450



Mounting the heater on the bracket (see detail in Fig. 7):

- Place the heater on the bracket and tighten assembly A (M8 screw + fan washer) using a 13 mm spanner.

- Align the heater in the chosen position.
- Secure assemblies A and B with a 13 mm spanner.

HORIZONTAL MOUNTING (FIG. 8):

- Choose the inclination of the bracket by fixing the strut (using two M8 x 120 screws) in the holes corresponding to the table below:

LOCATION	1	2	3	4	5	6	7
8	58°	80°	90° <small>vertical</small>			20°	30°
9	57°	67°	72°	78°		40°	43°

For horizontal mounting (0°), use the holes at Locations 9 and 3 without using the spacer.

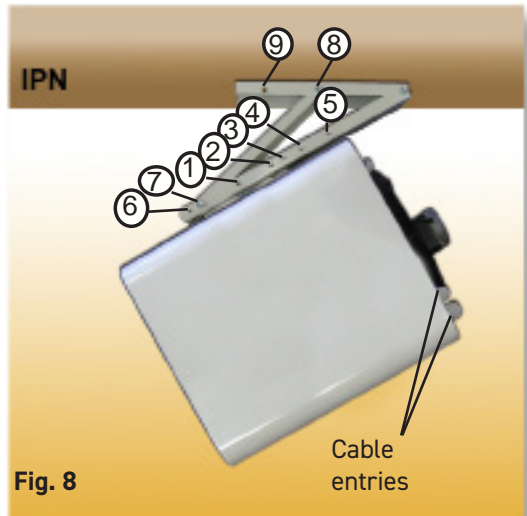

Fig. 8

Cable entries

4 - CONNECTION AND SERVICE

ELECTRIC CURRENT TABLE:

NOTE: The current drawn by the motor and relays is less than 2A for all appliances.

- The wiring of the heaters must comply with the standards in force in the country where the appliance is installed (NFC 15-100 for France). Cross-section and protection of the conductors in relation to the electric current table opposite.

- The cable entries are located at the rear of the heater.

- The heaters should be connected and the voltage changed as shown in Fig. 11.

- To access the terminal block, loosen the 9 screws securing the top cover.

- Remove the levelling screw for closing the grille and then remove the top cover.

- The heaters are delivered for 3-phase 400V + Neutral.

- The mains supply wires should be connected to the terminal blocks provided, taking care to tighten the screws securely.

Rated power of the heater	Heating modes	CURRENT ABSORBED PER PHASE	
		230 V SINGLE PHASE	400 V THREE PHASE
		1	13,04 A
2	19,57 A	3 x 6,49 A	
3 / 4,5 KW	1	17,39 A	2 x 8,66 A
	2	26,09 A	3 x 8,66 A
4 / 6 KW	1	26,09 A	2 x 12,99 A
	2	39,13 A	3 x 12,99 A
6 / 9 KW	1	26,09 A	2 x 17,32 A
	2		3 x 17,32 A
8 / 12 KW	1		3 x 10,83 A
	2		3 x 21,65 A
7,5 / 15 KW	1		3 x 12,99 A
	2		3 x 25,98 A
9 / 18 KW	1		3 x 17,32 A
	2		3 x 34,64 A
12 / 24 KW	1		
	2		

Fig. 10

Cable entries

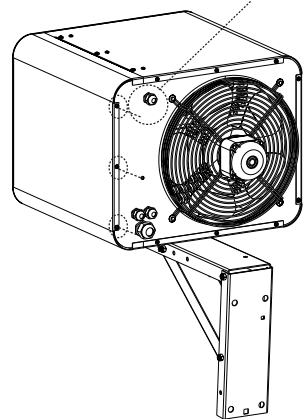

IMPORTANT:

It is essential to keep the phases in order when powering several heaters on the same control box.

Voltage changes:

Comply with figure 11 below:

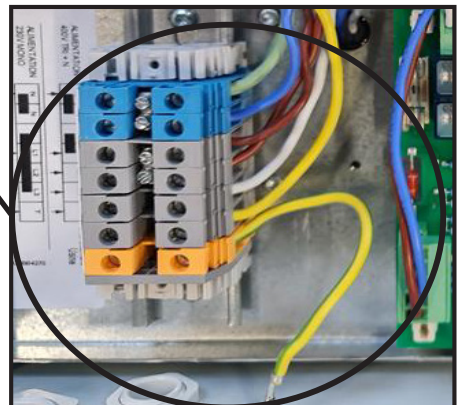
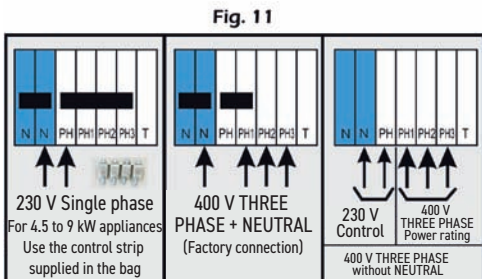

Wiring diagram 4.5 / 6 / 9 / 12 kW

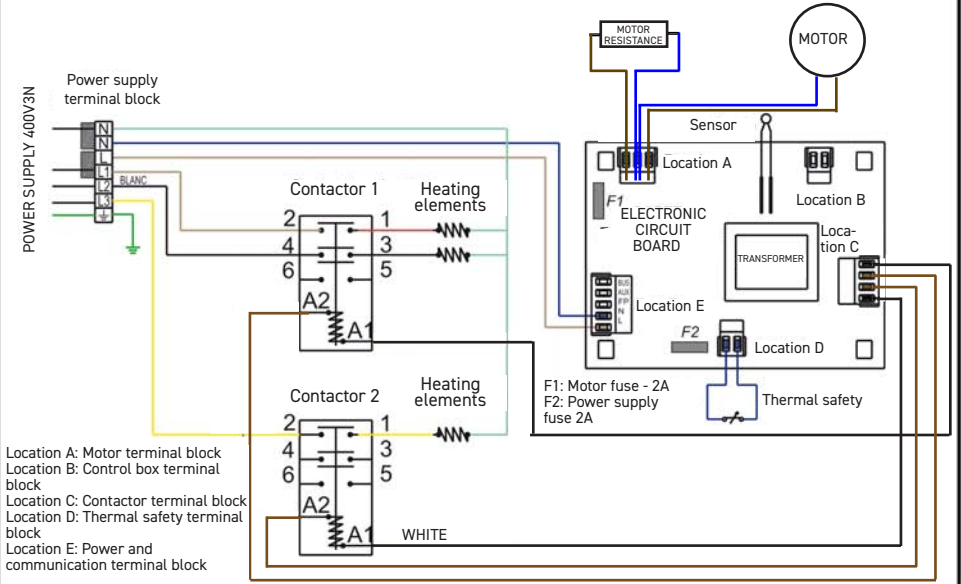

Wiring diagram 15 / 18 / 24 kW

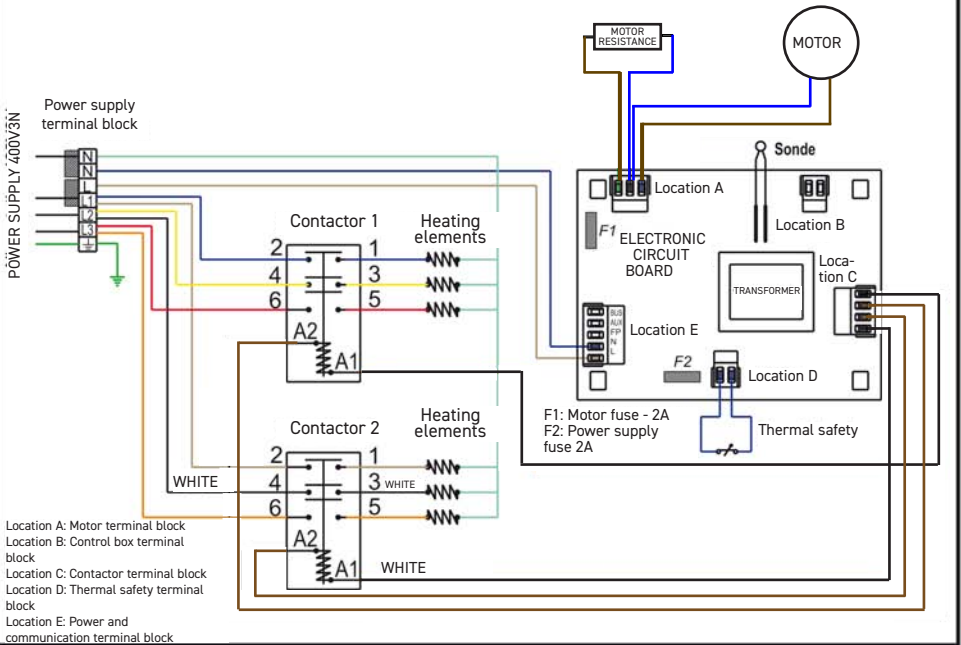

5 - OPERATION WITH A DIGITAL CONTROL BOX

CONTROL BOX

- The control box is fitted with a digital display showing the various operating modes.
- It is connected to the appliance with just two non-polarised low-voltage wires.
- The control box can be used to control up to 20 heaters in the same room.



- 1- Start/Stop Heating/Ventilation button
- 2 / 3 - "-" and "+" buttons
- 4- Display screen
- 5- Operating mode selection knob

Dimensions (L x W x D): : 147 x 71 x 28 mm

Mounting the control box

The control box can either be wall-mounted using its bracket (1) or inserted into standard flush-mounted wall boxes (2).

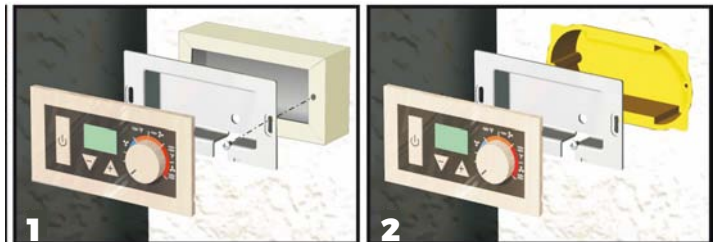

MOUNTING

Mounting on a wall surface:

- The control box is delivered as standard with a wall adapter for mounting on any wall (Fig. 2):

1 - Pass the 2 power supply wires from the control box through "hole 1" or "hole 2" depending on the configuration of the installation (pierce the cover of the grommet if you use "hole 1").

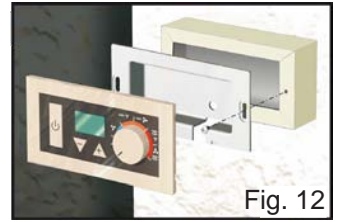

Fig. 12

2 - Screw the wall adapter (A) to the wall using two screws up to 05.5mm (B) not delivered with the kit.

3 - Use a screwdriver to separate the back of the control box (C) from the front panel (E) (Fig. 14).

4 - Route the power supply wires through their opening in the base of the box, then screw the base to the wall adapter using the 2 sheet metal screws. (D: delivered in the bag).

5 - Insert the power supply wires into the terminal block entries on the front of the box (see Fig. 15).

6 - Clip the front cover onto the base of the box.

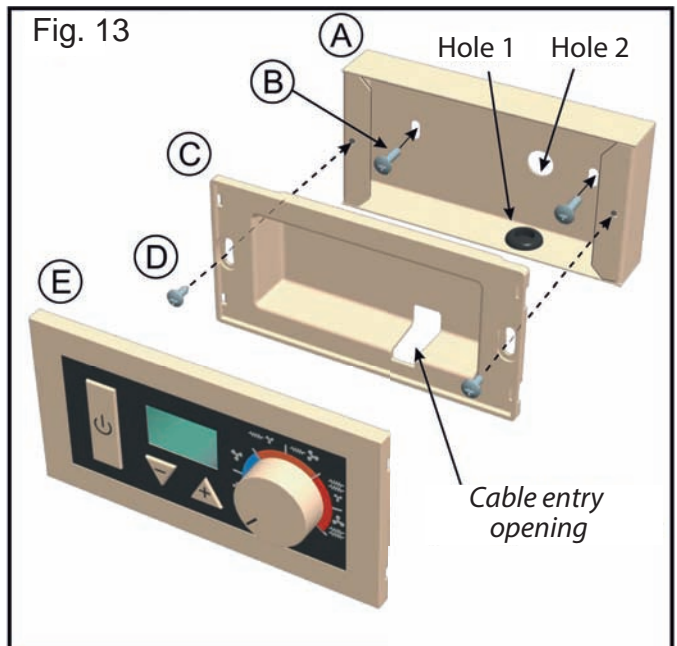

Fig. 13

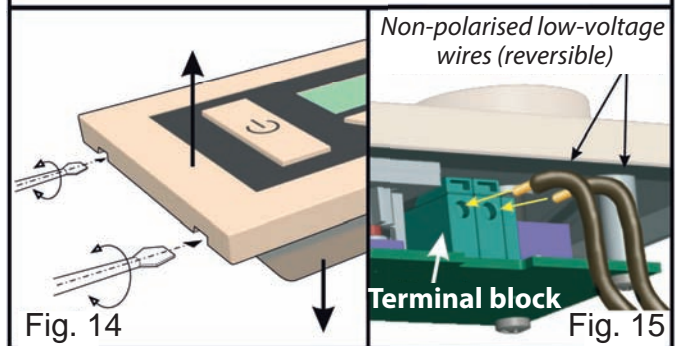

Fig. 14

Terminal block

Fig. 15

Installation in a standard flush-mounted wall box:

- 1 - Use a screwdriver to separate the back of the control box from the front panel (Fig. 14).
 - Route the power supply wires through their opening in the base of the box (Fig. 13), then screw the base to the flush-mounted box using the 2 screws (D).



- 2 - Insert the power supply wires into the cable entries on the terminal block (see Fig. 15) fixed to the front panel.
- 3 - Clip the front cover onto the base of the box.

CONNECTION

- Connect the appliance as shown in the diagram below:

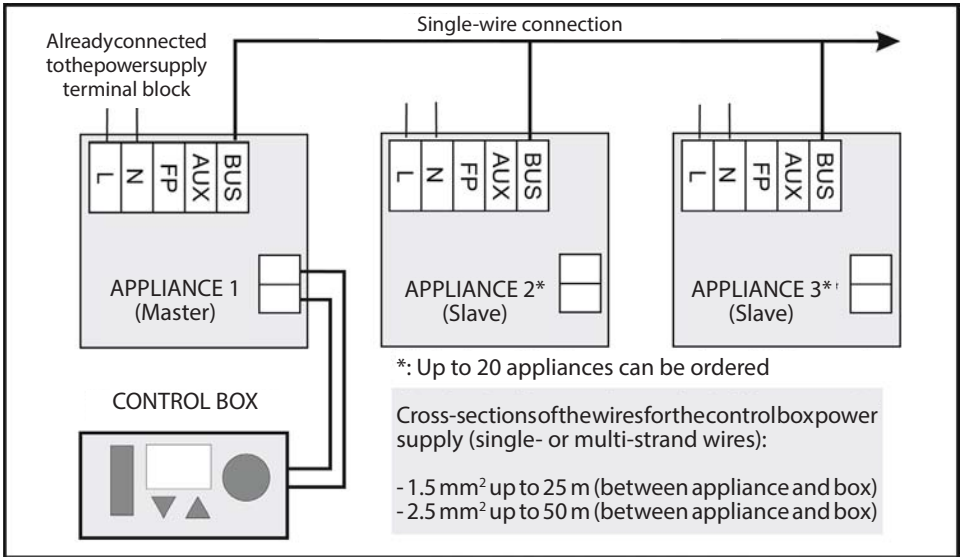

Before switching the system on, it is essential to finish connecting the wiring of the entire system so that the control mode can be properly recognised.

CONTROL BOX CONNECTION REF: M090010

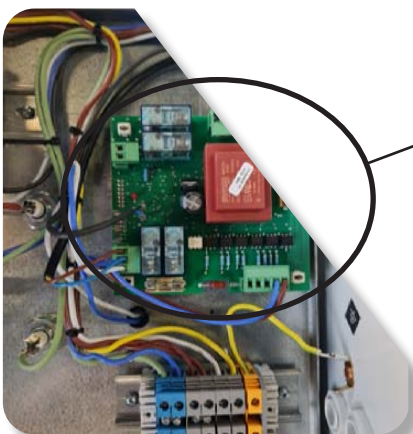

Non-polarised low-voltage electronic control box cable entries

A - BUS
B - AUX (Auxiliary) entry
C - FP entry (Pilot Wire)

OPERATION WITH A CONTROL BOX

Switching on:







- To switch on the control box, press the on/off button 
The screen lights up.

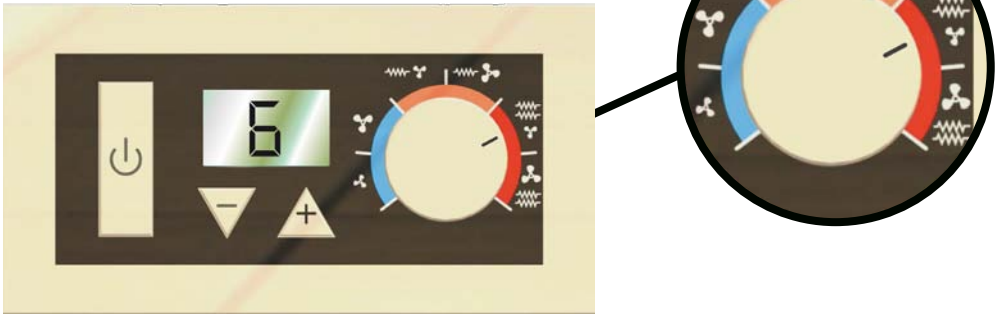

Operation in manual mode:

Selecting the operating mode:

Set the adjustment knob to the desired operating mode:



-  : Room temperature air ventilation with low fan speed
-  : High-speed room temperature air ventilation
-  : Low heating power with low fan speed
-  : Low heating power with high fan speed
-  : High heating power with low fan speed
-  : High heating power with high fan speed

NOTE: On zones  and  (blue zone) the unit blows air at room temperature.
The display shows "Fd" (Cold).



Selecting the desired set point:

Use the "+" and "-" buttons. Use them also to change the thermostat setting in steps from 1 to 9. Set the box to 9 to ensure that the blown air is always warm. If the room is too hot, reduce the setting by one step. If it is still hot in the room, repeat the operation until a satisfactory temperature is reached.

Switching off:

Press the  button to turn off the appliance(s).

As soon as you press the button:

- The system stops after approximately 3 seconds when operating in cold ventilation mode.
- If the appliance is heating up, the heating elements switch off and the ventilation stops after about one minute (the time for the heat contained in the heating elements to dissipate).

During this time, the display will show a rotating propeller icon and then the appliance will switch off.



Locking the control box:

Press the "+" and "-" buttons simultaneously. Repeat the operation to unlock. The display shows "bLo" when a button is pressed while the control box is locked, and "dEb" when it is unlocked.



"locked"

This lock blocks all the functions of the control box (changing the position of the knob will have no effect).



"unlocked"

Heating indicator:

When the appliance is heating up (i.e. the heating elements are working), a black dot appears at the top left of the screen.



Sensor fault:

The message "EE" appears if there is a problem with the appliance sensor.

The installation stops for as long as the problem persists.



Operation with pilot wire control:

Switching on:

A programmer (GIFAM commands or MDE manager) must be connected to the electronic circuit board of the master appliance (FP input).

Programmer commands take precedence over the control box.

The control box will automatically detect commands sent by the programmer (Comfort, Eco, Frost protection, Comfort -1°C and -2°C, Heating Off).

Programming commands:

COMFORT: the display shows the selected set point step.



ECO: Eco lowers the set point temperature (Comfort position) by 3.5°C. The display shows "ECO".



COMFORT -1°C or -2°C: the display shows "CF1" or "CF2" and the temperature is adjusted to 1 or 2 °C below the set point temperature.



FROST FREE: the display shows "HG" and the temperature is adjusted to a set point temperature of 7°C.



OFF: the display shows "OFF", the heating elements stop working and the motor continues to run for a few seconds (about 3 seconds in the room temperature air ventilation position or about 1 minute in the heating position) for the heat contained in the heating elements to dissipate.



Other functions:

For pilot wire control, the functions described in the "Manual Operation" section apply. However, the set point can only be adjusted and the appliance can only be calibrated (see below) in Comfort mode.

Select the desired room temperature (see programme 01 on page 20). Use the "+" or "-" buttons to change the desired room temperature setting.

The temperature is set from 0.5°C to 0.5°C and the setting range extends from 7°C to 27°C. Press and hold to scroll the display (from 0.5°C to 0.5°C).



Calibration of the desired room temperature (See programme 01 on page 20)

Press the  button for 3 seconds. The set point temperature display will flash.

Use the "+" and "-" buttons to calibrate the temperature in 0.5°C steps within a range of ±2°C of the set point.

Press  to return to the initial menu.

This adjustment can only be made with a set point between 17°C and 22°C.



"locked"

Outside this range, after pressing the  button for 3 seconds, the display will not flash and will show "BL0".

If the "+" and "-" buttons are not pressed for 15 seconds, the control box display will return to the main menu.

Choice of operating programme:



You can choose the operating programme for your appliance as follows:

- **PROGRAMME 01:** Operation with power and ventilation cut-off.

- **PROGRAMME 02:** Operation with power cut-off and continuous ventilation. This programme is recommended for destratification.

- **PROGRAMME 04:** Works in the same way as programme 01, but the step number is displayed instead of the temperature.

To change the programme:

- 1 - Press and hold the  and "-" buttons simultaneously for 3 seconds. The screen will flash the number of the installed programme.
- 2 - Press the "+" and "-" buttons to obtain the required programme number.
- 3 - Press the  button to confirm the selection.



6 - SPECIAL CASES

CONNECTION WITH A THERMOSTAT:

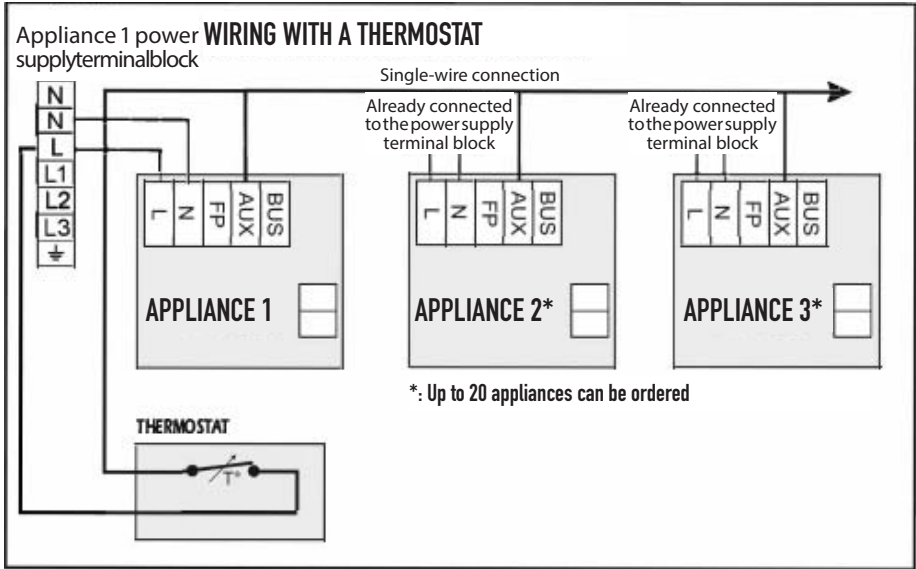

CONNECTION FOR DIRECT OPERATION:

- Add a shunt between the "AUX" terminal on the electronic circuit board terminal block and the "L" (phase) terminal on the appliance power supply terminal block.

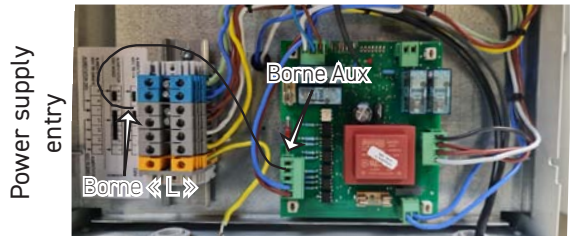

REMOTE SENSOR

A wall-mounted sensor kit (optional) may sometimes be required for installations that do not comply with installation or insulation regulations, or when the difference between the temperature displayed by the box and the actual temperature is too great.

7 - MAINTENANCE

This robustly built appliance requires no maintenance. However, in dusty environments the rear grille needs to be cleaned regularly.

IMPORTANT: Before carrying out any work on the appliance, it is essential to switch off the power supply using the omnipolar isolating switches on the electrical panel (power and controls).

8 - APPLIANCE IDENTIFICATION



IMPORTANT: The characteristics of the appliance are shown on the information plate attached to the rear of the appliance near the cable entries.

